

atriadesigns.ca



premier outdoor living • solar shading • cladding products

(604) 428 1818

sales@atriadesigns.ca

Premium

Outdoor Glass Systems



miba
CREATING OUTDOOR EXCELLENCE



Technical Information

Motor Box dimensions: 130 x 145

The Motor Box features an openable cover for easy maintenance access. It can be secured with screws on the top or, alternatively, mounted directly to the vertical guide rails using a special bracket.

Bottom Bar dimensions: 127 x 43

The bottom bar enhances system stability and provides effective water insulation. It also facilitates easier adjustments on uneven surfaces, ensuring a precise fit.

Vertical Channel dimensions: 124 x 84 mm

The vertical channel houses the motion belt while also stabilizing both the fixed and retractable panels. It is composed of four distinct profiles, designed to simplify installation.

Glass dimensions:

5+14+5 double glass with tempered on both sides.

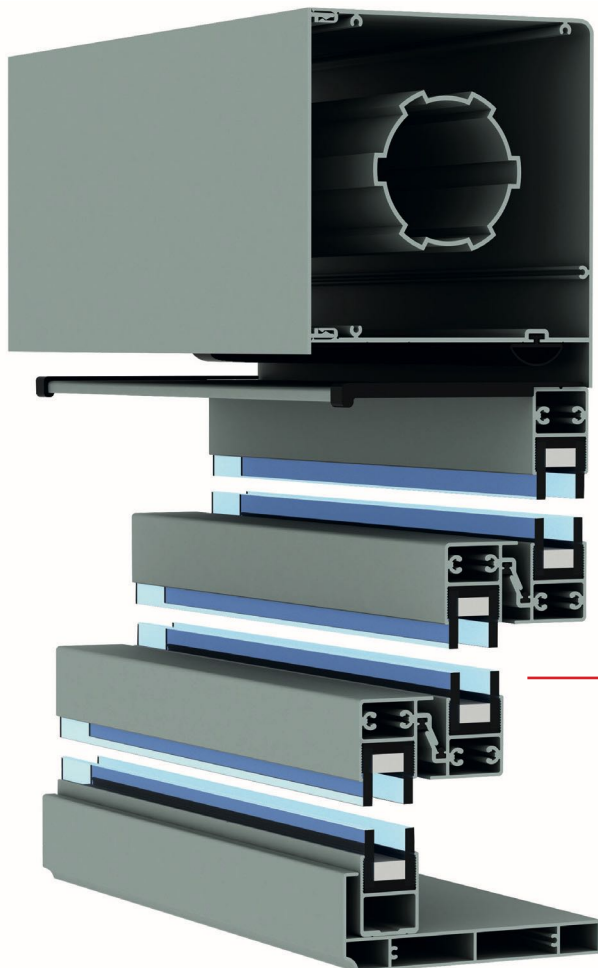
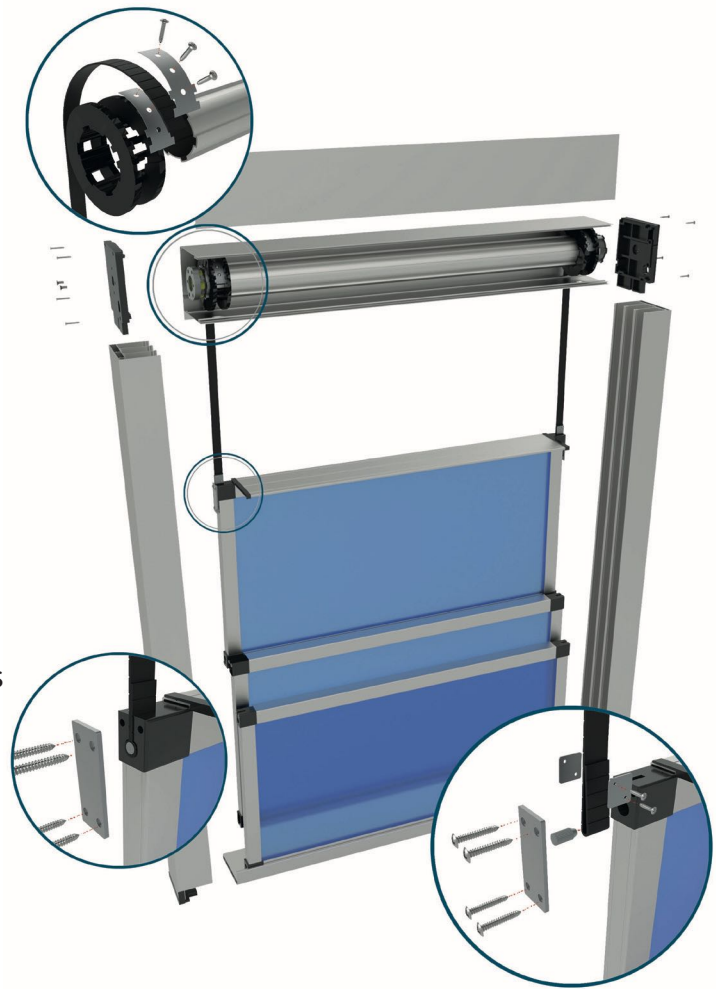

- Motor Box 130X150
- Slim perimeter profiles 35mm
- 5+14+5 tempered glass
- Bottom Bar

High Low^{2.0}

technical details



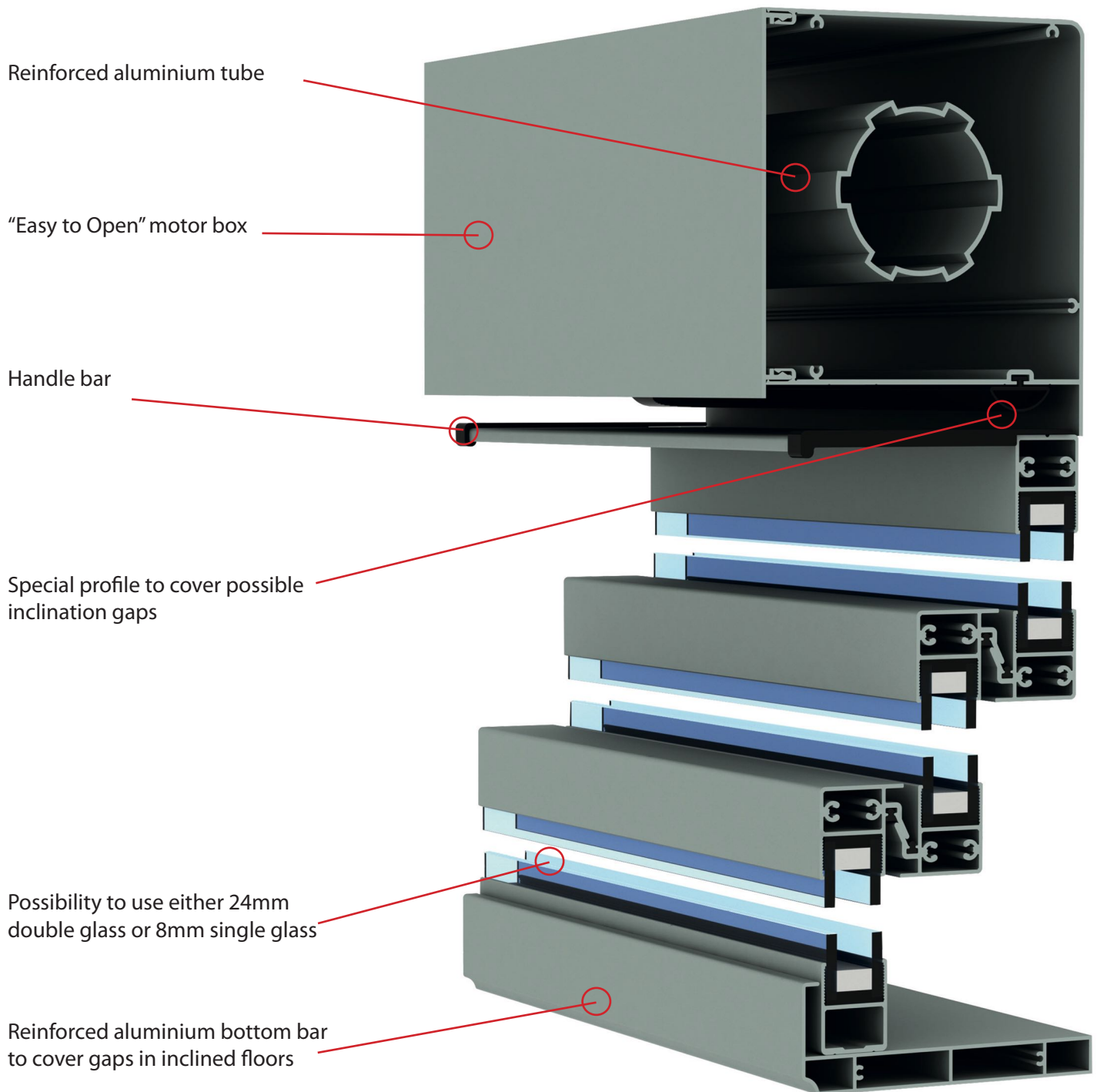

Additional Characteristics

- > Operation with Somfy motor
- > Belt or chain options are available (Belt is standard)
- > Reinforced glass profiles for enhanced safety during retraction
- > Vertical runners with concealed protective covers
- > Effortless manufacturing with seamless connections
- > Quick installation with detachable runners

High Low2.0 technical details

Profiles Sections

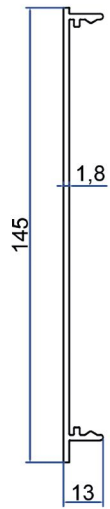

Box Cap profile

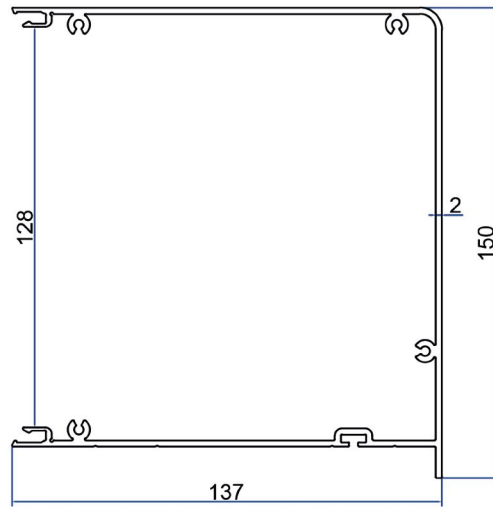

Motor Box profile

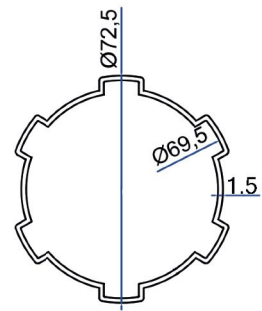

Tube

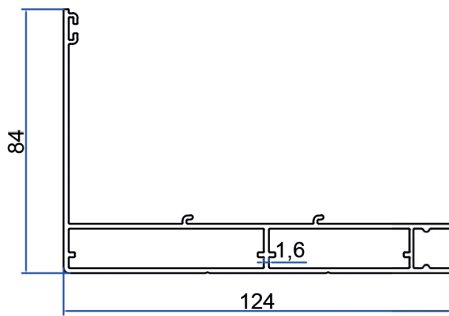

Runner profile

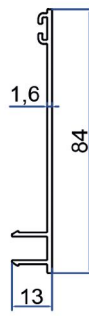

Runner Cap profile

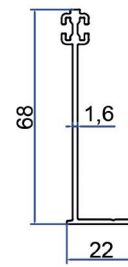

Additional Runner profile



Gap cover profile

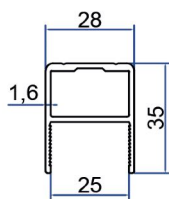

Top & Bottom glass profile

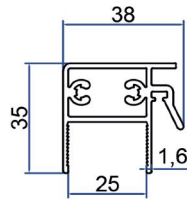

Intermediate glass profile

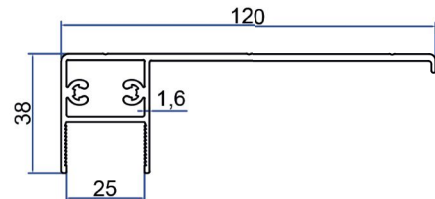

Handlebar profile

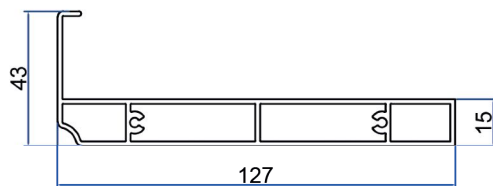

Bottom Base profile

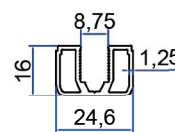

8mm glass adaptor profile

3D Profiles Sections



Motor Box profile



Box Cap profile



Handlebar profile



Runner Cap profile



Additional Runner profile



Top & Bottom glass profile



Runner profile



Gap cover profile



Intermediate glass profile



Bottom Base profile



Tube



8mm glass adaptor profile

Motor Box with chain - Exploded

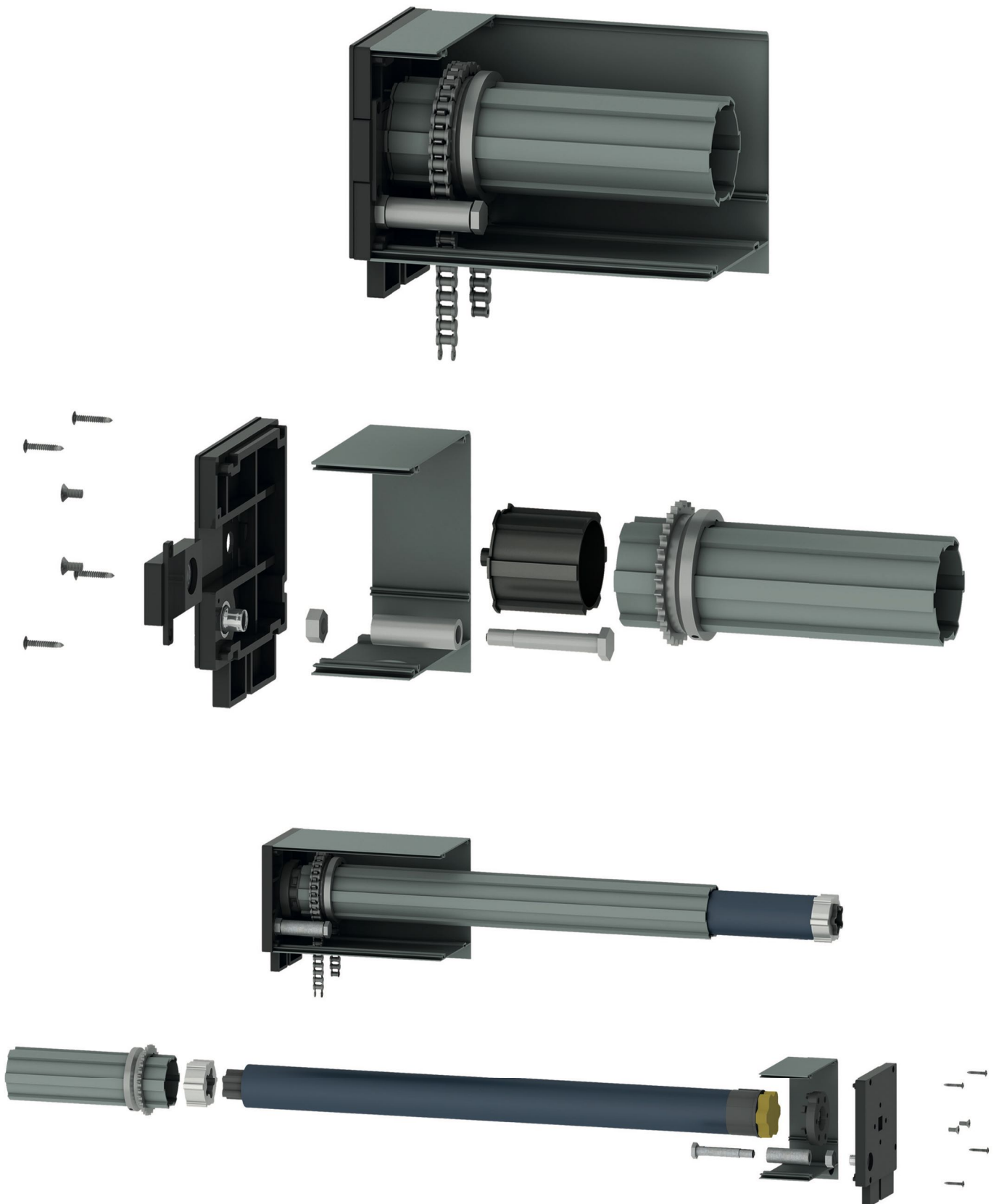

High Low2.0 technical details

Full system with belt - Exploded (standard)

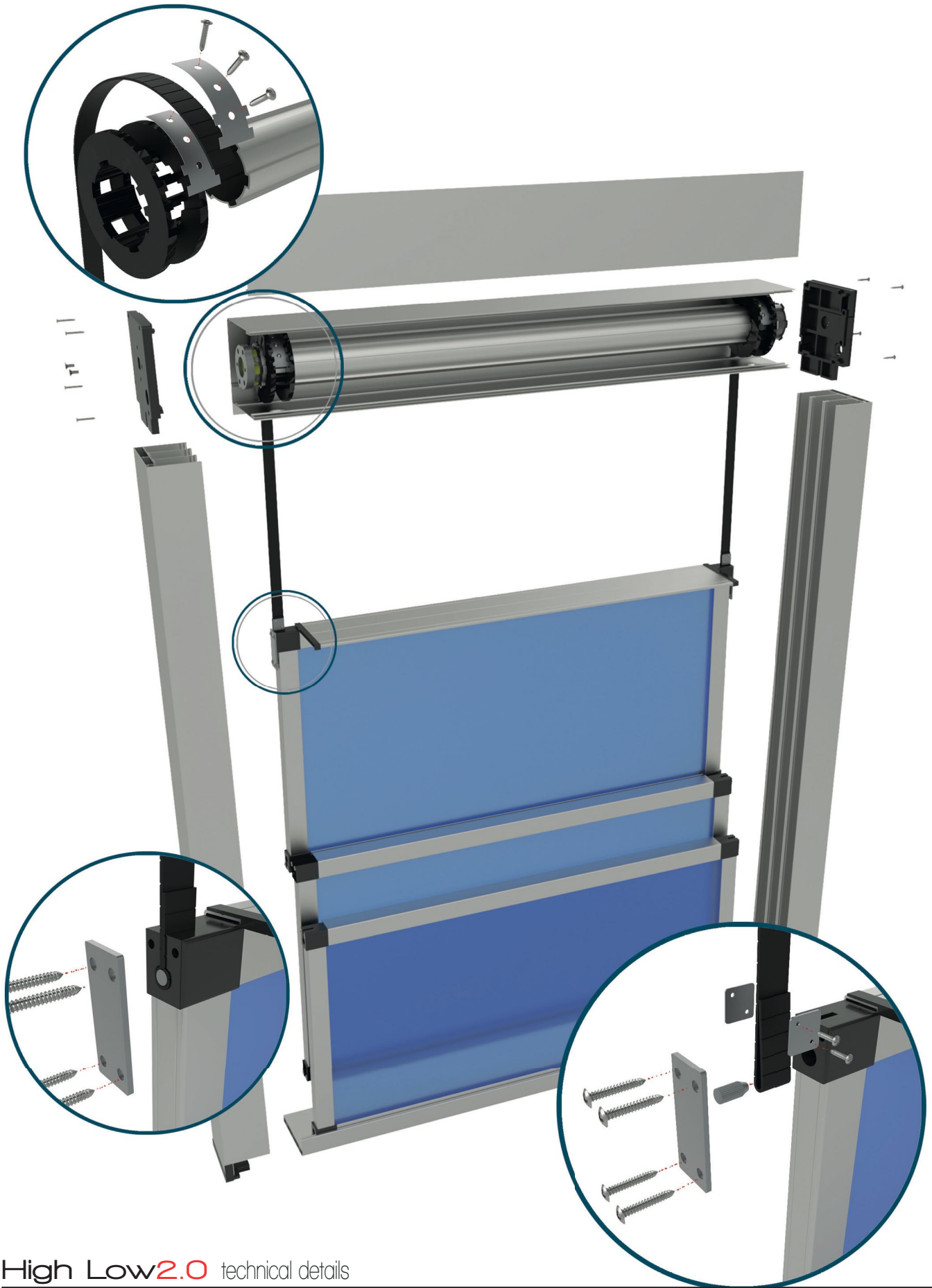

High Low2.0 technical details

Full System with chain- Exploded



High Low2.0 technical details

Glass assembly - Exploded

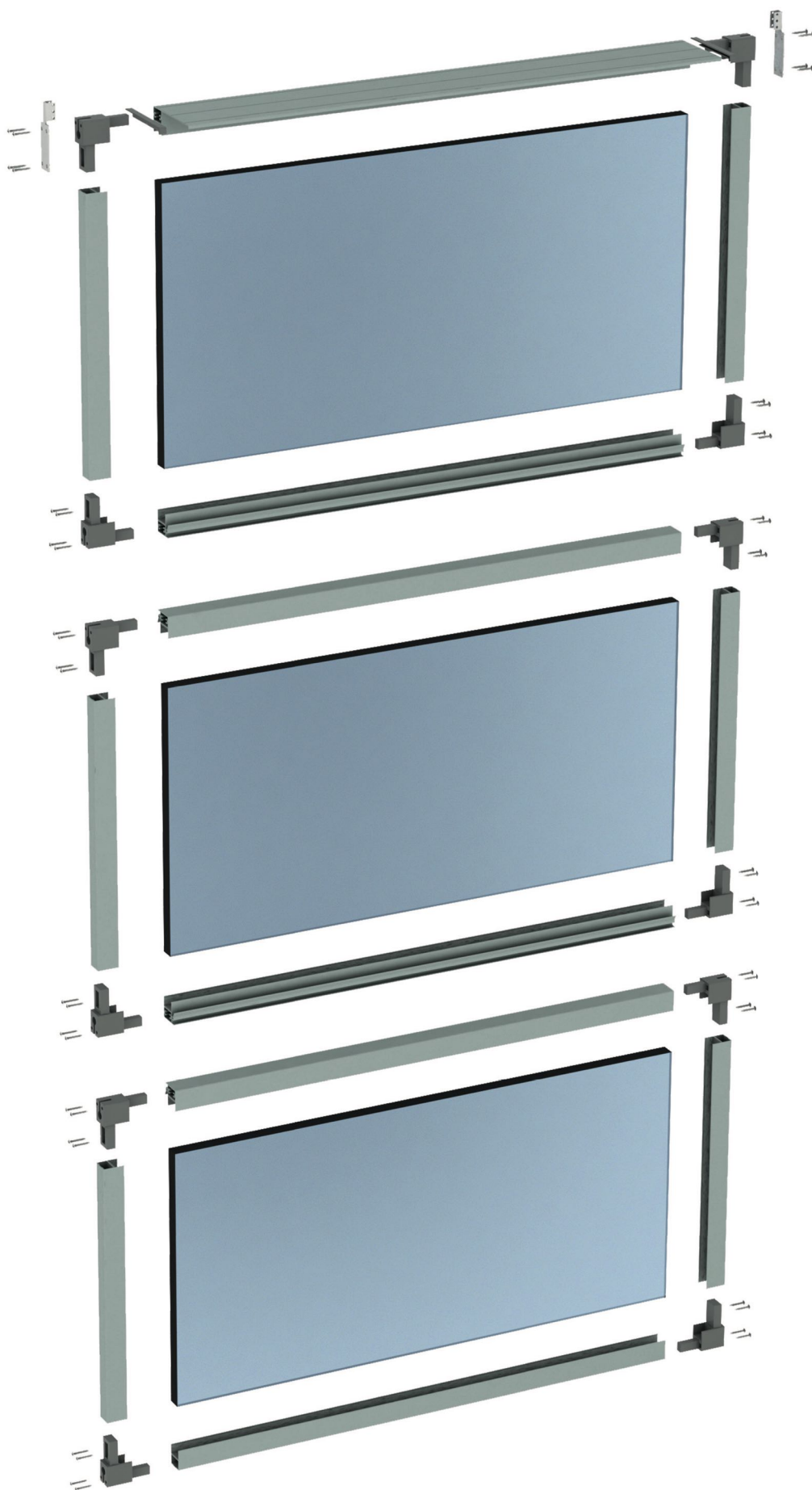

High Low2.0 technical details



miba
CREATING OUTDOOR EXCELLENCE

miba
CREATING OUTDOOR EXCELLENCE